

# MDS250 68" Refrigerated Open Display, Grab & Go

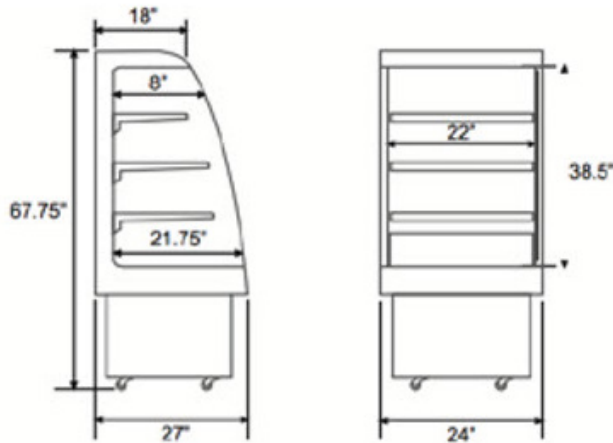

Great for Drinks, Fruits, Vegetables, Salads & Dairy



## Product Features

- *Internal LED Lighting*
- *Adjustable Temperature Control*
- *Adjustable Shelving*
- *Pull Down Night Shade*
- *Automatic Defrost*
- *Stainless Steel Construction*
- *Casters Installed Standard*

## Specifications

DIMENSIONS (WDH)	. . . 24" x 27" x 67.75"
WEIGHT	. . . . . 282 lbs
SHELVES	. . . . . 3 Adjustable + Base
SHELVES SIZE	. . . . . 12" x 21.75" (Top)
	. . . . . 15" x 21.75" (Bottom)
TEMPERATURE	. . . . . 37°F ~ 54°F
TEMP CONTROL	. . . . . Digital
CAPACITY	. . . . . 252L / 9 Cu F
REFRIGERANT	. . . . . R404a
PACKAGING (WDH)	. . . 30" x 28" x 70"
SHIP WEIGHT	. . . . . 298 lbs
ELECTRICAL	. . . . . 110 V / 60 / 1
RATED CURRENT	. . . . . 10 Amps
WARRANTY	. . . . . 1 Year Warranty, 3 Year Compressor